

**PLEASE READ AND FOLLOW ALL WARNINGS**



**Low Speed Tire Buffer**

**Read Operating Instructions**

Always become familiar with all the instructions and warnings before operating any power tool.



**Always Wear Approved Eye Protection**

Impact resistant eye protection should meet or exceed the standards as set forth in the United States ANSI Z87.1, Occupational and Educational Eye and Face Protection. Look for the marking Z87.1 on your eye protection to insure that it is an approved style. For further information, ANSI Z87.1, Occupational and Educational Eye and Face Protection, is available from the American National Standards Institute, Inc., 11 West 42nd Street, New York, NY 10036.



**Hearing Protection is Recommended**

Hearing protection should be used when the noise level exposure equals or exceeds an 8 hour time-weighted average sound level of 85 dBA. Process noise, reflective surfaces, other tools being operated nearby, all add to the noise level present in your work area. If you are unable to determine your noise level exposure, we recommend the use of hearing protection.



**Avoid Prolonged Exposure to Vibration**

Tools can vibrate during use. Prolonged exposure to vibration or very repetitive hand and arm movements, can cause injury. Stop using any tool if discomfort, tingling feeling or pain occurs. You should consult your physician before resuming use of the tool.



**90 PSIG Maximum**

This tool is designed to operate at

an air pressure of 90 pounds per square inch gauge pressure (90 PSIG) maximum, at the tool. Use of higher air pressure can, and may cause injury. Also, the use of higher air pressure places the internal components under loads and stresses they were not designed for, causing premature failure. The air supply should be clean and dry, preferably lubricated. For best results, drain the moisture from your compressor daily.

**WARNING:**

Some dust created by power sanding, sawing, grinding, drilling, and other construction activities contains chemicals known to cause cancer, birth defects or reproductive harm. Some examples of these chemicals are:

- Lead from lead-based paints
- Crystalline silica from bricks, cement and other masonry products
- Arsenic and chromium from chemically treated lumber

Your risk from these exposures varies, depending on how often you do this type of work. To reduce your exposure to these chemicals, work in a well-ventilated area and work with approved safety equipment such as those dust masks that are specially designed to filter out microscopic particles.

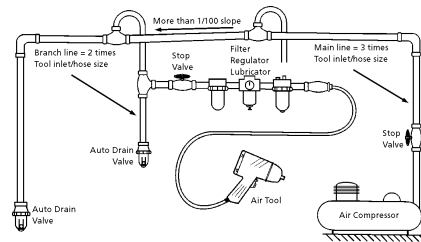

**Description**

Florida Pneumatic tire buffer features low speed motor. Ideal for preparation of all rubber surfaces.



**Safety Instructions**

The following instructions are furnished as general guidelines for use of your pneumatic tool. They cannot comprehensively cover all possible or conceivable uses of the subject tool. For additional information on the safe use of air tools, we advise you to obtain a copy of ANSI B186.1 Safety Code for Portable Air Tools, available from the following source:

American National Standards Institute, Inc.  
11 West 42nd Street  
New York, NY 10036.

The use of the word "shall" in the following instructions, indicates that adherence to the particular requirement is necessary to conform to ANSI B186.1.

**Tool Application and Usage**

Portable tools shall be used only for the purposes intended in their design and within the capacity for which they were intended and rated. It shall be the tool owner's and/or employer's responsibility to instruct each operator in the safe use of the tool. Tools shall not be used without guards and safety

devices as furnished by the manufacturer. Where an air tool is modified or altered, the modifier shall provide the safeguards to enable it to be safely used in the operations intended and to comply with any applicable provisions as contained in ANSI B186.1.

**Tool Installation**

Pressure regulators shall be used to limit air pressure to the rated pressure where the supply pressure exceeds the tool's rated pressure. Air hoses and lines shall be relieved of compressed air before being disconnected or disjoined, unless there is automatic valve closing protection at the joint being separated. Synthetic lubricants which can cause deterioration of elastomer seals shall not be used in air systems of air tools.

**Tool Maintenance**

It shall be the tool owner's and/or employer's responsibility to assure that tools are maintained in a safe operating condition. Tool maintenance and repair shall be performed by authorized, trained, competent personnel. Tools shall be disconnected from their compressed air supply before repairs are attempted. Repairs shall be consistent with the manufacturer's recommended procedures. Tool, hoses and fittings shall be replaced if unsuitable for safe operation. It shall be the tool owner's and/or employer's responsibility to keep required rating markings and warnings on the tool in legible condition.

Florida Pneumatic Manufacturing Corporation  
851 Jupiter Park Lane, Jupiter, Florida 33458  
Toll Free 1-800-327-9403

*Read these instructions carefully before attempting to install, operate or service this Florida Pneumatic product. Failure to comply with the instructions could result in personal injury and/or property damage! Retain these instructions for future reference.*



Chuck size.....5/16" Int. Hex  
 Free speed .....4,500 RPM  
 Weight.....2 1/4 lbs.  
 Overall length.....9 1/2"  
 Recommended hose size.....3/8" I.D.  
 Diameter.....1-1/2"  
 Air inlet.....1/4" NPT  
 Maximum operating pressure.....90 PSI

**Parts Breakdown for FP755**

**Note:** always use accessories with an RPM rating that meets or exceeds the tool RPM rating. Always examine accessories before mounting for chips, cracks, or signs of damage. Never use accessories that have been dropped or exposed to; water, solvent, or extreme temperature changes. It is a good practice to operate the tool in a protected enclosure for one minute after mounting any accessory.

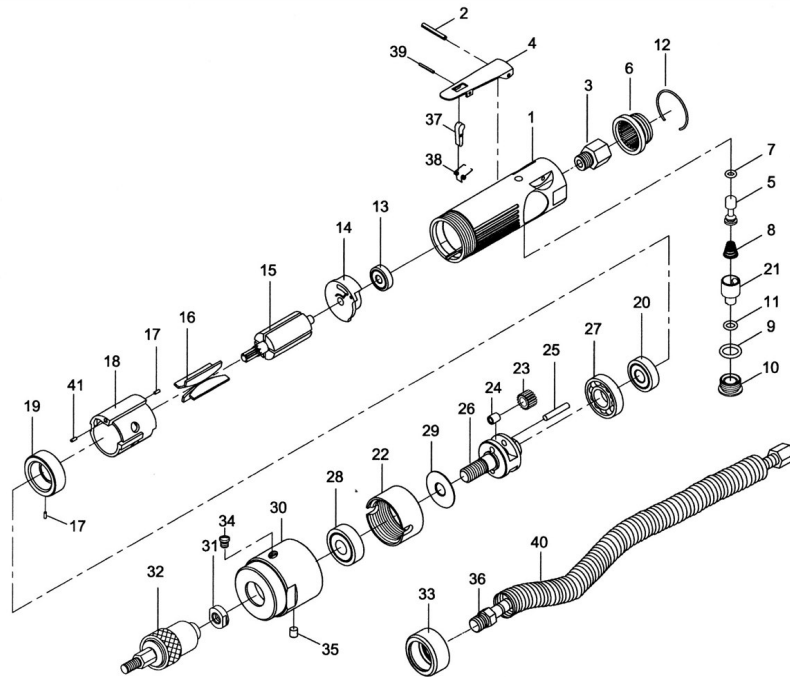

**Replacement Parts for FP755**

Ref.	Description	Part #	Ref.	Description	Part #
1	Motor Housing	970627	23	Planet Gears (3)	974625
2	Spring Pin	930102	24	Bushing (3)	974625
3	Air Inlet	970628	25	Pin (2)	970125
4	Throttle Lever	953204	26	Planet Cage	974626
5	Valve Stem	951705	27	Ball Bearing	8729478
6	Exhaust Diffuser	970629	28	Ball Bearing	9051220
7	O-Ring	970107	29	Washer	974624
8	Valve Spring	951208	30	Front Housing	974630
9	O-Ring	970123	31	Chuck Spacer	972529
10	Throttle Valve Plug	951210	32	Tire Buffer Head	966130
11	O-Ring	940305	33	Clamp	951243
12	Retaining Ring	970630	34	Oil Screw	972935
13	Ball Bearing	9030113	35	Oil Cap	952237
14	Rear End Plate	951214	36	Hose	970632
15	Rotor	970615	37	Safety Bar	951540
16	Rotor Blade (4)	951216	38	Spring	651541
17	Spring Pin (2)	970117	39	Spring Pin	951542
18	Cylinder	970118	40	exhaust Hose	970633
19	Front End Plate	970619	41	Spring Pin	920448
20	Ball Bearing	8729020			
21	Air Regulator	951221			
22	Internal Gear	974622			

**Limited Warranty**

Florida Pneumatic warrants its tools to be free from defects in material and workmanship for two years from the date of purchase. This warranty does not apply to tools which have been abused, misused, modified or repaired by someone other than Florida Pneumatic or its authorized service centers. If a Florida Pneumatic proves defective in material of workmanship within one year after purchase, return it to any authorized service center or to Florida Pneumatic, freight prepaid. Please enclose your name, address and adequate proof of purchase date with a brief description of the defect. Florida Pneumatic will, at its option, repair or replace defective tools, free of charge. Repairs or replacements are warranted as described above for the remainder of the warranty period. Florida Pneumatic's sole liability and your exclusive remedy under this warranty is limited to repair or replacement of the defective tool. There are no other warranties expressed or implied and Florida Pneumatic shall not be liable for incidental, consequential or special damages, or any other damages, costs or expense of repair or replacement as described above.